

INSTRUCTION MANUAL

Orion® SteadyPix™ EZ Smartphone Telescope Photo Adapter

#5347



 **ORION**
TELESCOPES & BINOCULARS
AN EMPLOYEE-OWNED COMPANY

Corporate Offices: 89 Hangar Way, Watsonville CA 95076 - USA
Toll Free USA & Canada: (800) 447-1001
International: +1(831) 763-7000
Customer Support: support@telescope.com

Copyright © 2020 Orion Telescopes & Binoculars. All Rights Reserved. No part of this product instruction or any of its contents may be reproduced, copied, modified or adapted, without the prior written consent of Orion Telescopes & Binoculars.

Introduction

Congratulations on your purchase of the Orion SteadyPix EZ Smartphone Telescope Photo Adapter! It's an improved design that is simple to use, sturdy, and is compatible with even the biggest smartphones on the market today -- phones up to 8.3" x 4.7". The SteadyPix EZ securely couples your smartphone to a standard 1.25" telescope eyepiece, enabling the capture of high-magnification digital photographs through the telescope using the smartphone's built-in camera. Use it with telescopes, spotting scopes, binoculars, or even monoculars – in day-time or at night. It holds your phone's camera steady and in exactly the correct position relative to the instrument's eyepiece to give a perfectly framed and focused image shot after shot – which is virtually possible when trying to hold the phone up to the eyepiece by hand.

The SteadyPix EZ also lets you display a live view of the image projected by your telescope on your smartphone screen, which is perfect for sharing real-time views of the Moon or planets with friends and family. The smartphone becomes a mini display monitor!

We hope you have fun taking pictures with your smartphone using the SteadyPix EZ!

Compatibility

The Orion SteadyPix EZ is designed to fit slate style (flat) smartphones measuring **from 4.7"x2.4" up to a maximum of 8.3"x4.7"**. The phone's camera lens should be oriented near the top of the back side for unobstructed alignment with a telescope eyepiece.

The SteadyPix EZ was designed with an adjustable bracket to allow compatibility with most currently available smartphones, including large ones like the iPhone 6s Plus and Samsung Galaxy Note 5.

For best results we recommend removing any case or bumper from the phone before installing it in the SteadyPix EZ. Even if the phone fits with the case left on, it may prevent the phone's camera lens from getting close enough to the telescope eyepiece, which could result in a constricted "keyhole" field of view on the phone screen (**Figure 1A**). When the camera is allowed to get as close as possible to the telescope's eyepiece, the image from the telescope will fill up much more of the phone's screen (**1B**).

The SteadyPix EZ can be used with virtually any size or type of telescope – refractor, reflector, or Cassegrain-type – that utilizes a standard 1.25"-diameter telescope eyepiece.

WARNING: Never look directly at the Sun through your telescope or its finder scope—even for an instant—without a professionally made solar filter that completely covers the front of the instrument, or permanent eye damage could result. Young children should use this telescope only with adult supervision.

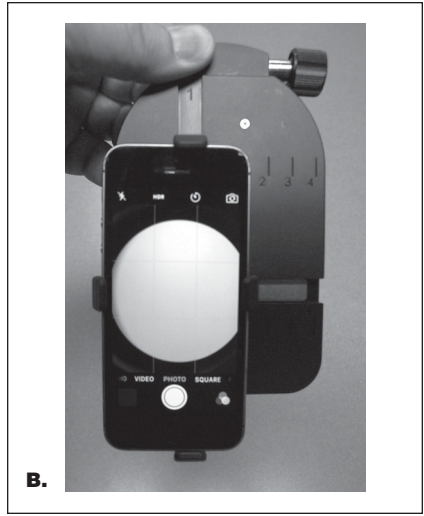

Figure 1. Removing the bumper or case from your smartphone may avoid a constricted field of view as in **A**. With case or bumper removed the image will fill more of the phone's screen, as in **B**.



Figure 2. Examples of two eyepieces with housing diameters that are compatible with the SteadyPix EZ. The 25mm Sirius Plossl (right) has a housing diameter of 35mm; the 3mm Edge-On Planetary eyepiece has a housing diameter of 45.5mm. Both eyepieces are shown with their rubber eyecups removed.

The included eyepiece clamp fits eyepieces with housing diameters from **31mm to 55mm** (**Figure 2**).

NOTE: If the eyepiece you're using has a rubber eyecup, it may be necessary to remove it so that it does not interfere with proper clamping and positioning of the eyepiece in the SteadyPix EZ. You can re-attach the eyecup once you're finished using the SteadyPix EZ

Getting Started

The SteadyPix EZ comes pre-assembled. See **Figure 3** to familiarize yourself with its parts.

To capture images through your telescope, spotting scope, or binoculars, both its eyepiece and the smartphone's camera lens must be precisely centered relative to the round hole in the SteadyPix EZ's plate. First, position the smartphone as follows:

1. Loosen the phone clamp knob on the back of the SteadyPix.
2. Place your phone against the plate with screen facing up (**Figure 4A**).
3. Move the phone so that the camera lens is centered in the hole in the back plate, when viewed from the back side of the SteadyPix (**4B**). Then slide the side and end clamps inward so they grip the phone in that position.
4. Tighten the phone clamp knob.
5. Confirm that the phone is held securely in the clamps on all sides. The clamps are rubber covered and angled inward to prevent the phone from slipping out, no matter what the angle.

Now you will clamp the SteadyPix EZ onto the eyepiece of your telescope, spotting scope, or binocular. For a telescope or spotting scope eyepiece, it may be easiest to remove the eyepiece from the scope and install it in the SteadyPix, then re-insert the eyepiece in the scope with SteadyPix and phone attached. Binocular eyepieces are not removable.

1. Looking at the back side of the SteadyPix, rotate the eyepiece clamp knob counterclockwise to move the three clamp posts outward far enough to fit over the eyepiece.
2. Place the eyepiece, with top end down, over the hole in the SteadyPix, making sure the eyepiece is resting against the SteadyPix (**Figure 5A**).

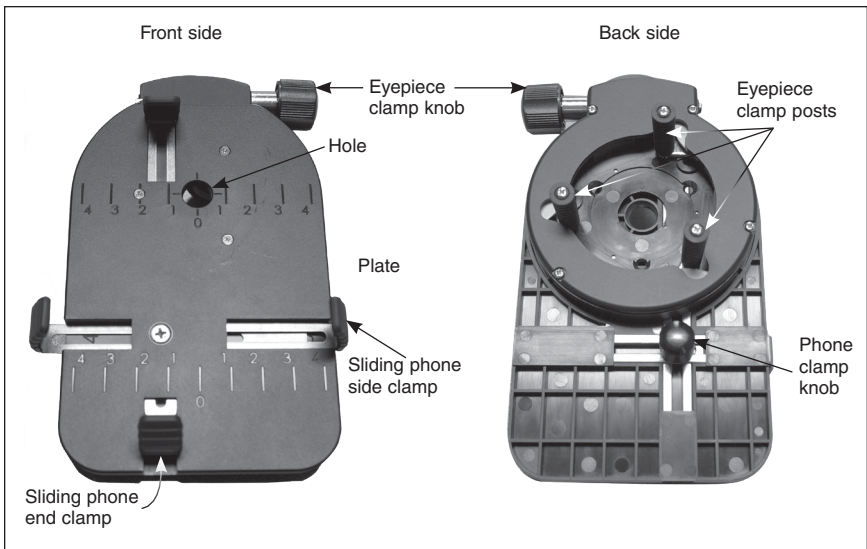

Figure 3. Parts of the SteadyPix EZ

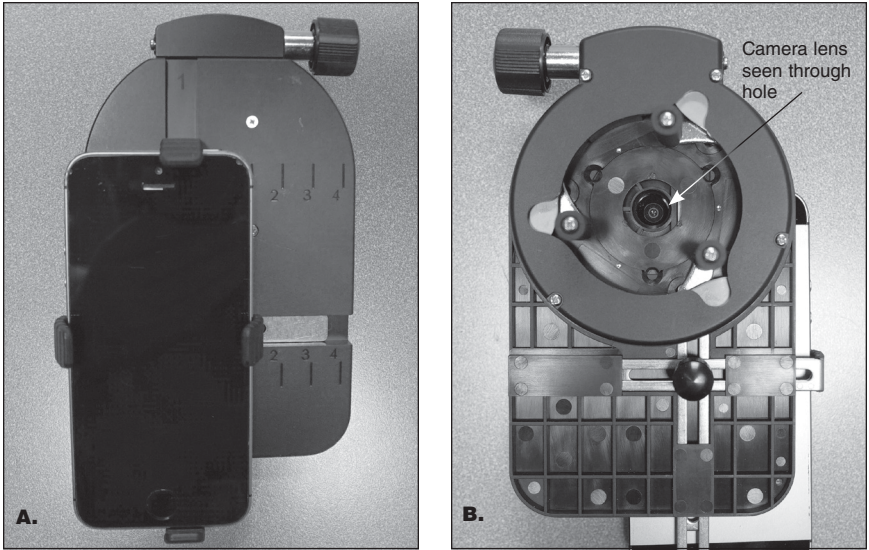

Figure 4. Center the phone's camera lens in the hole in the SteadyPix EZ's plate.

3. Now turn the eyepiece clamp knob clockwise until the three rubber-covered clamp posts achieve a secure grip the eyepiece (**5B**). *Do not overtighten, though!* The inward-moving posts will center the eyepiece over the hole in the SteadyPix.

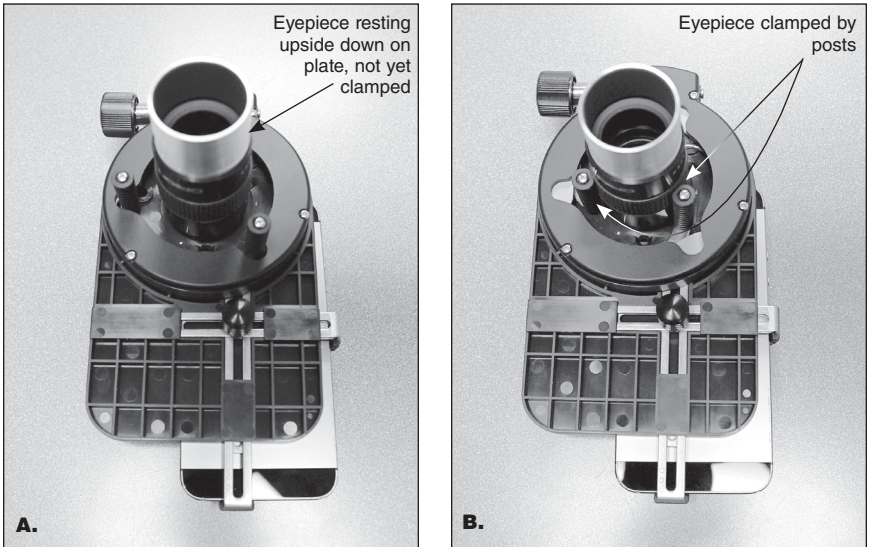

Figure 5. A) Place the eyepiece upside down on the SteadyPix as shown, then **B)** rotate the eyepiece clamp knob clockwise until the three clamp posts grip the eyepiece housing firmly.

We recommend starting with a fairly long focal length eyepiece, such as a 25mm. Once you get the hang of it, you could swap it out for shorter focal length, higher-power, eyepieces such as a 15mm or 10mm, which usually have smaller eye lenses.

4. Now check the alignment by turning on the camera app in your phone. You should see a distinct, bright “field of view” circle (possibly clipped on the edges) centered on the phone’s display (**Figure 1B**). (Nothing in the field of view will be in focus at this point!) If needed, you can adjust the position of the phone after first loosening the phone clamp knob, until the field of view is precisely centered on the phone’s LCD screen. Then re-tighten the phone clamp knob.
5. Now you’re ready to install the eyepiece and phone assembly into the telescope’s focuser or diagonal. Carefully insert the eyepiece into the focuser or diagonal and secure it firmly with the locking thumbscrew(s) on the focuser or diagonal (**Figure 6**).
6. With the telescope aimed at a fairly bright object and with the camera app turned on, use the telescope’s focuser to bring the object into focus on the smartphone’s display.

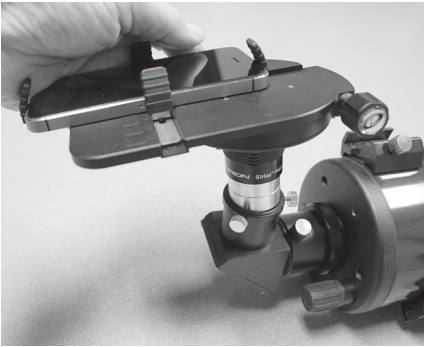

Figure 6. Insert the eyepiece with SteadyPix and phone attached into the star diagonal and secure it tightly with the thumbscrews. Before doing this be sure that the diagonal is tightly secured in the telescope’s focuser!

Taking Photographs with the SteadyPix EZ and Your Smartphone

The higher the camera sensor's resolution, i.e., the more megapixels it has, the better your smartphone photos are likely to be. That is, an 8MP camera should produce a sharper, more resolved image than a 2MP camera. If your phone has a flash, make sure the flash is turned off when shooting through a telescope eyepiece!

Use exposure delay, also called a self timer. The vibration from the tapping the phone to take an image is enough to cause blurring of the image, if the exposure occurs immediately. Having a delay of a few seconds between the screen tap and the onset of exposure eliminates the problem by allowing any vibration to dissipate prior to image capture. If your phone's native camera function does not have an exposure delay feature, there are plenty of third-party camera apps that do.

Moon: Our closest neighbor in the solar system is dazzling through even a very small telescope. The SteadyPix will allow you to take beautiful images of the whole Moon or close-ups that showcase the craters, mountains, or maria (**Figure 7**). Single snapshots work well and multiple shots can be stacked later in a program such as Registax to increase the signal-to-noise ratio and dynamic range of the image. Also, you can take video and then stack a series of the sharpest individual video frames.

Bright Planets: The bright planets Venus, Mars, Jupiter and Saturn also make excellent targets for afocal photography. Try using a higher power eyepiece and maybe a Barlow lens to boost the magnification – planets are tiny objects in the sky! You'll need a steady atmosphere, i.e., good “seeing,” to get sharp planetary images. The smartphone's display will allow you to show off your target object to friends and passers-by—no waiting in line at the eyepiece!

Deep-sky Objects: Most deep-sky objects are difficult to photograph using a smartphone. Try working with brighter objects such as M42 (Orion Nebula) or M13 (Hercules Cluster). You will likely need a mount that tracks the motion of the sky so that you can take “long” exposures using a 3rd-party app that offers that capability (try Slow Shutter by Tomoki Kobayashi), and you will have to stack multiple images to get a good final image.

Sun: If – and only if! – you have a proper solar filter to cover the front of your telescope, you can get terrific images of sunspots on the surface of our nearest star in the daytime with your smartphone. Sunspots are constantly changing, so shooting them is always interesting and a lot of fun.

Nature/Terrestrial: The SteadyPix EZ can be used to take through-the-telescope photos and videos of distant subjects in daylight.

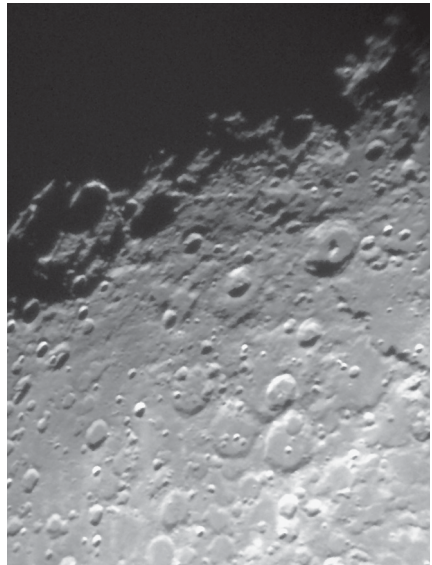

Figure 7. Lunar close-up taken with iPhone 5s mounted in a SteadyPix EZ attached to an 85mm refractor. Magnification: 112x.

One-Year Limited Warranty

This Orion product is warranted against defects in materials or workmanship for a period of one year from the date of purchase. This warranty is for the benefit of the original retail purchaser only. During this warranty period Orion Telescopes & Binoculars will repair or replace, at Orion's option, any warranted instrument that proves to be defective, provided it is returned postage paid. Proof of purchase (such as a copy of the original receipt) is required. This warranty is only valid in the country of purchase.

This warranty does not apply if, in Orion's judgment, the instrument has been abused, mishandled, or modified, nor does it apply to normal wear and tear. This warranty gives you specific legal rights. It is not intended to remove or restrict your other legal rights under applicable local consumer law; your state or national statutory consumer rights governing the sale of consumer goods remain fully applicable.

For further warranty information, please visit www.OrionTelescopes.com/warranty.



Corporate Offices: 89 Hangar Way, Watsonville CA 95076 - USA
Toll Free USA & Canada: (800) 447-1001
International: +1(831) 763-7000
Customer Support: support@telescope.com

Copyright © 2020 Orion Telescopes & Binoculars. All Rights Reserved. No part of this product instruction or any of its contents may be reproduced, copied, modified or adapted, without the prior written consent of Orion Telescopes & Binoculars.